



AGNES / ASTRAL AGNES

triode<sup>3</sup> design

28, rue Jacob 75006 Paris  
+33 (0)1 43 29 40 05

contact@triodedesign.com  
www.triodedesign.com

## AGNES ASTRAL AGNES

Originally conceived as a candelabra, Agnes takes its inspiration from the fictional heroine of the same name, a worker in the world's oldest profession during the 1849 California Gold Rush. The modular system would allow Agnes easy setup in her makeshift "workspace." In this version, glowing glass tubes replace the candles. Articulated joints allow the glass to be arranged in a multitude of ways.

Chandelier — 20 Lights (Brushed Brass / Straight-Cut Glass)  
*Approx. L 59.5 in / 151 cm × W 50 in / 127 cm × H 33.5 in / 85 cm*

## Finishes

- Black
- Bronze
- Polished Nickel
- Brushed Brass

## Canopy



A

A 5-inch round in matching metal finish

## Features

Astral glass is fixed

## Lamping 120V



A

B

C

A 25-Watt T6 1/2 frosted tube E17 base. UL, cUL certified

B 25-Watt G9 Halogen

C 3-Watt G9 LED

## Lamping 240V

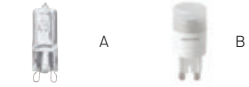

A

B

A 20-Watt G9 halogen. CE, CB certified

B 2.4-Watt G9 LED

## Glass Style

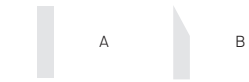

A

B

A Straight-cut

B Angle-cut

## Details

Lead Time	10 weeks
Materials	Machined aluminum, glass
Suspension	1/2-inch aluminum stem in matching metal finish. 35-inch length included with lamp. 96-inch length available for additional cost. Stem length can be adjusted on site.
Dimmer Compatibility	Triac or Electronic Low Voltage (ELV)

## Year

2010

## Designer

Lindsey Adelman designs and produces lighting in Manhattan. Lindsey discovered Industrial Design while working at the Smithsonian and introducing herself to a woman carving French fries out of foam for an exhibition. Thinking that looked like more fun than her editorial job, she left to get a degree in ID from the Rhode Island School of Design in 1996. Her work has been exhibited at the Cooper-Hewitt Museum, Design Miami, and Nilufar Gallery. Her body of work has grown to include vessels, jewelry, blankets, wallpaper, tiles, and video. Always asking the question "what if?" the studio now embraces a philanthropic mission supporting Robin Hood Foundation to fight poverty in NYC. She lives with her designer husband Ian and their son Finn in Brooklyn.

AGNES

13



Athlone Street — Vancouver

**Chandelier — 14 Lights (Brushed Brass / Straight-Cut Glass)**  
*Approx. L 72.5 in / 184 cm × W 34 in / 86 cm × H 21 in / 53 cm*

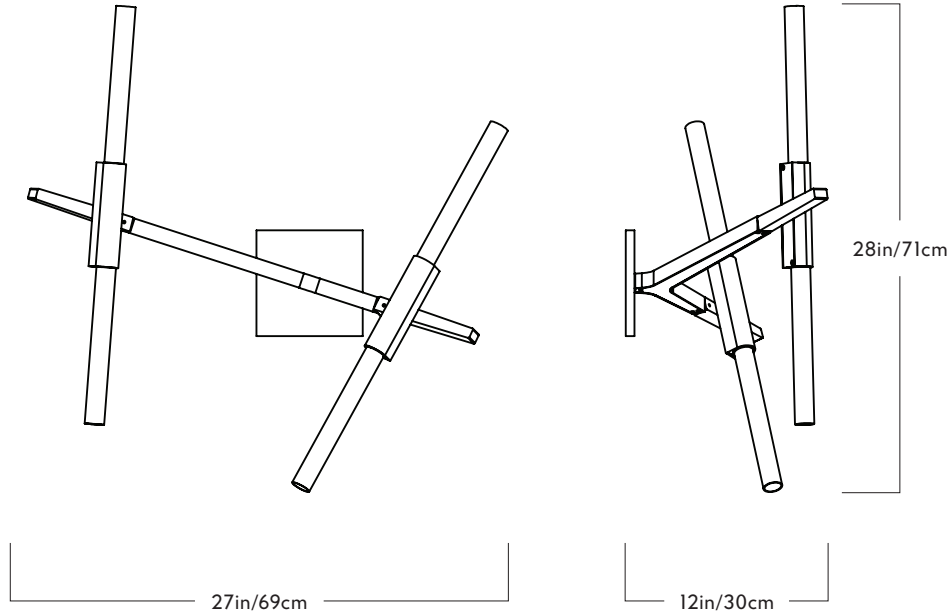

## Agnes

## Sconce - 4 Lights

Series  
Agnes

Materials  
Machined aluminum, glass

Incandescent Illumination (120V)  
Socket: E17

Product  
Sconce - 4 Lights

Finishes  
Black, bronze, polished nickel, brushed brass

Bulb: 4 x 25 Watt T6½ incandescent  
Wattage: 100 Watts  
Lumens: 560 Lumens  
Color Temperature: 2800

Lead Time  
8 weeks

Back Plate  
6-inch square in matching metal finish

Halogen Illumination (120V/240V)  
Socket: G9

Dimensions  
Appx. H 28in/71cm x W 27in/69cm x D 12in/30cm

Dimmer Compatibility  
Triac/Phase-Cut

Bulb: 4 x 20 Watt T4 halogen  
Wattage: 80 Watts  
Lumens: 720 Lumens  
Color Temperature: 2900 Kelvin

Weights  
8lb/3.5kg

Certifications  
UL, cUL (120V Incandescent)  
CE, CB (240V Halogen)

LED Illumination (120V/240V)  
Socket: G9  
Bulb: 4 x 3 Watt T6 LED  
Wattage: 12 Watts  
Lumens: 880  
Color Temperature: 2700 Kelvin

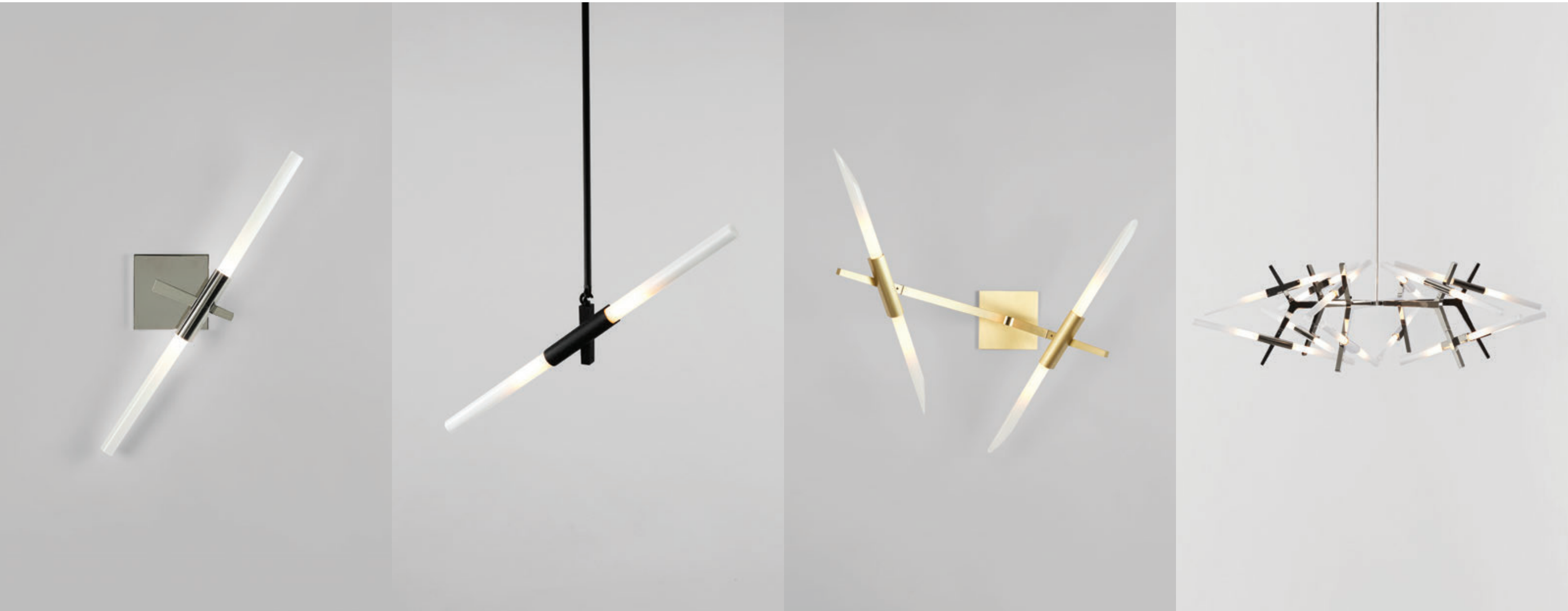

Sconce — 2 Lights (Polished Nickel / Straight-Cut Glass)  
*Approx. H 27 in / 69 cm × W 8 in / 20 cm × D 5 in / 12 cm*

Pendant — 2 Lights (Black / Straight-Cut Glass)  
*Approx. L 24.5 in / 63 cm × W 3.5 in / 8 cm × H 15 in / 37 cm*

Sconce — 4 Lights (Brushed Brass / Angle-Cut Glass)  
*H 28 in / 71 cm × W 27 in / 69 cm × D 12 in / 31 cm*

03 – 24 Lights (Polished Nickel)  
*Dia 60 in / 152 cm × H 17 in / 43 cm*