

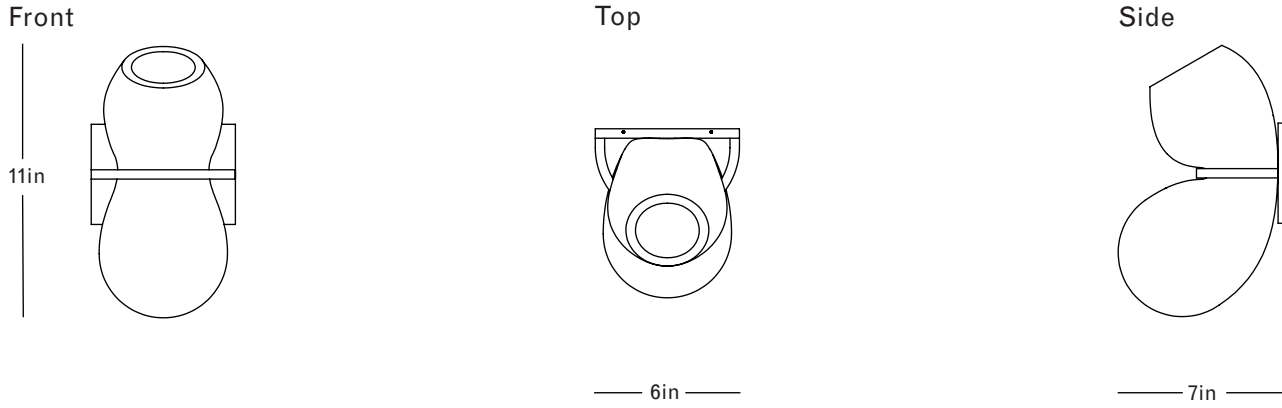

Brushed Brass
White Glass



Finish Palette



Brushed Brass



Satin Nickel



Vintage Brass

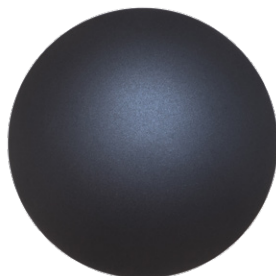

Oil Rubbed Bronze



White Glass

Specifications

DIMENSIONS

Height: 11in / 28cm
 Width: 6in / 15cm
 Depth: 7in / 18cm
 Weight: 5lb / 2.3kg

MOUNTING

H4in x W5.75in Backplate

MATERIALS

Machined brass, hand-blown glass

BULBS

G9 / 110v / 1.8w / 2700k / dimmable LED
 G9 / 220v / 1.8w / 2700k / dimmable LED
 Maximum Fixture Wattage: 25w



UL, cUL (120V) Certified

Inspiration

The Catch collection conveys fluidity with a poetic vividness. What animates the collection is a sense of enlivening, even precarious balance between structure and illumination. The metal structure remains solid and steadfast, but the glass is ever-elusive and alchemical. Might it, if only in the imagination, fall through the yoke or swell to bursting? Could it dissolve into a luminous pool?