

Drift Pendant 30"

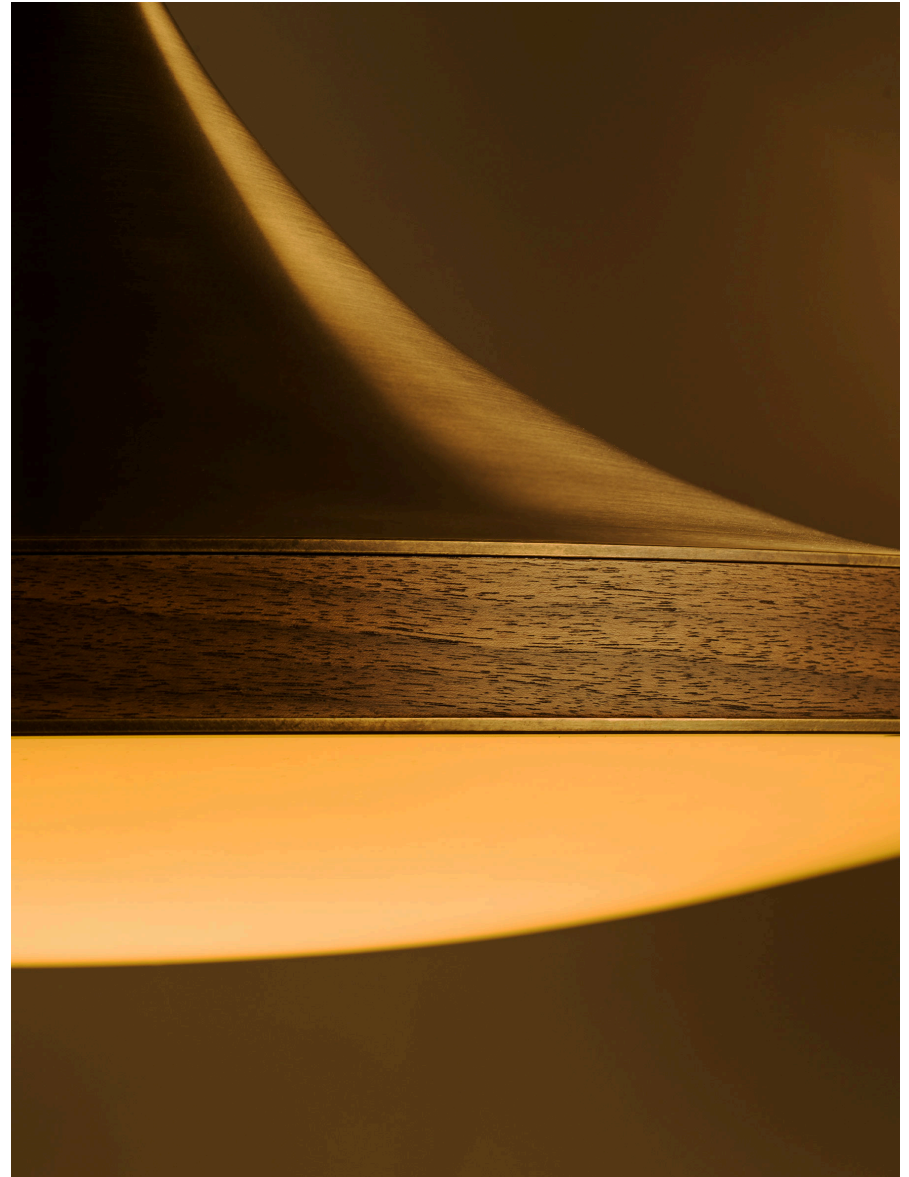

ALLIED MAKER

CEI-184



Drift Pendant 30"



ALLIED MAKER

CEI-184

DESCRIPTION

The Drift Pendant is a large-diameter statement piece defined by a smooth, aerodynamic taper that flows from the hang tube down into the center of the fixture. This continuous curve creates a refined transition and a distinctly streamlined silhouette, giving the form a sense of motion and ease. At its core, the spun form resolves into a precisely machined solid aluminum body, wrapped in hardwood veneer to introduce warmth and material contrast. This central element anchors the piece before giving way to a hand-slumped glass diffuser below. The generously scaled diffuser emits an even, ambient light, casting a soft, warm glow that enhances the pendant's calm, cohesive presence.

MOUNTING HARDWARE DIAGRAM

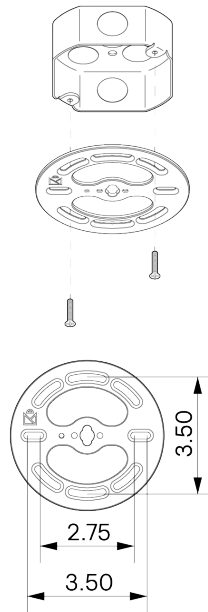

LAMPING

E26 or E27 Screw Base. Type A Lamps

BULB INCLUDED (120V USA)

Satco 13.5W Bulb

BULB INCLUDED (240V EU)

Emery Allen 8.5W 240V Bulb

LAMP QUANTITY

2

BRIGHTNESS

3200 Lumens

MAX WATTAGE

20W

DIMENSIONAL DRAWING

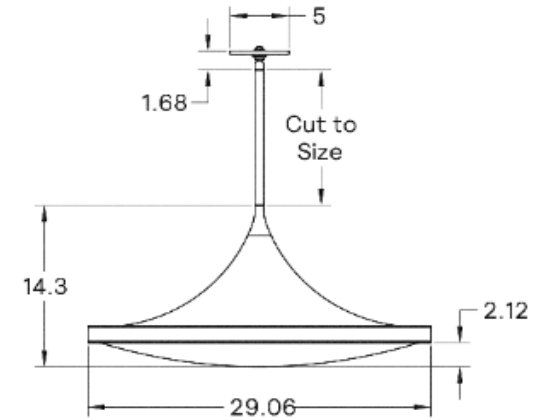

MATERIALS

Brass, Glass, Wood Veneer

METAL FINISHES

Available in All Standard Metal Finishes

GLASS FINISHES

Matte White, Opal

WOOD FINISHES

Available in All Standard Wood Finishes
SALES@ALLIEDMAKER.COM

MOUNTING

Universal

WEIGHT

42 lb

DIMMING

Universal Dimming

CERTIFICATIONS

CE, Damp Locations, UL and cUL Certified

